

# CONTROL BOARD MANUAL

Two-Axis 4.0 Control Board

控制板说明书

## Product Parameter

|                   |   |
|-------------------|---|
| Product Name:     | 2 Axis 4.0 Control Board                          |
| Specifications:   | 2 Axis  |
| Package Size:     | 185mm*115mm*55mm                                  |
| Package Weight:   | 200g  |
| Product Size:     | 133mm*40mm  |
| Product Weight:   | 120g  |
| Operating System: | Windows/Linux/Mac                                 |
| Interface Type:   | Type-B  |
| Supply Voltage:   | DC12V-5A  |
| Software Support: | LaserGRBL(Windows)<br>LaserWeb(Windows/Linux/Mac) |

## Wiring Diagram

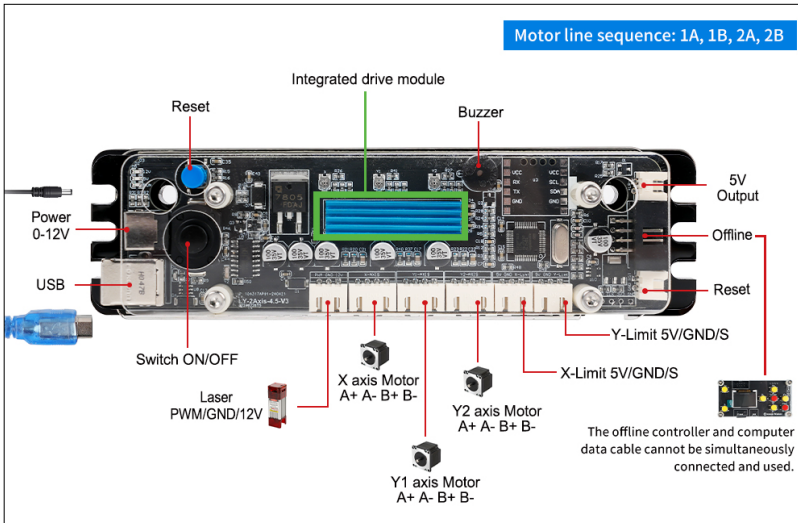

## Product Accessories



## Product Feature

- ARM32-bit control board
- One-piece integrated drive
- PWM output frequency 10kHz, high precision
- Y-axis dual drive, stronger drive capability
- Support USB automatic identification, automatic shielding offline interface
- 5V power output port, convenient to expand various functions
- Support USB flash firmware, firmware upgrade is more convenient
- XY limit switch interface each
- Built-in laser anti-burn mode

## Free Software

Link 1 - <https://1bestlinks.net/RDIHv>

Link 2 - <https://1bestlinks.net/SQYOS>

# Machine Wiring Diagram

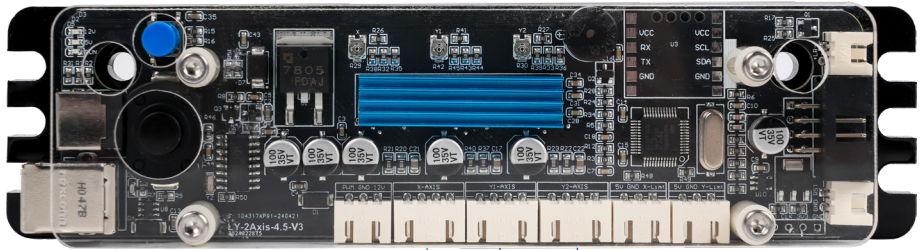

X axis

Y1 axis

Y2 axis

